

Introduction

Welcome to the world of OFYR.

Our story began in 2015 with a dream to transform outdoor cooking from a solitary activity into a shared experience. This vision came to life with the OFYR Classic, an iconic open fire plancha that became the predecessor for a formidable range of outdoor cooking units and furniture.

Over the years, our products have brought people together around the fire, creating unique culinary moments all year long. And we keep pushing forward, with a desire to introduce our definition of the art of outdoor cooking to gardens all over the world.

There is no better way to discover this art than with OFYR Cozinha. This collection of outdoor kitchens is skilfully designed to harmoniously blend form and function in a luxurious way. Each model offers the perfect culinary oasis for those who relish the great outdoors and appreciate the finer things in life. Whether you are looking to host a dinner party or want to unwind with the family on a summer afternoon, OFYR Cozinha is the key to bringing people together for a culinary adventure.

Our collection is available in various colourways and formats, allowing you to choose an outdoor kitchen that perfectly meets your taste and needs. At the heart of each kitchen is an integrated cooking device – an OFYR Plancha or The Bastard VX ceramic barbecue. Whatever model you are interested in, the high-end design of the OFYR Cozinha will seamlessly blend with the existing architecture and landscape, becoming a stunning extension of your home.

Get ready to explore new ways of cooking and entertaining outdoors, indulging in the luxury and functionality of the OFYR Cozinha collection.



Table of contents

About the OFYR Plancha	10
<i>Cooking techniques</i>	12
<i>Perfect plancha experience</i>	14
About The Bastard Kamado	16
<i>Cooking techniques</i>	18
<i>The perfect kamado experience</i>	20
Materials	22
OFYR Cozinha Elba	24
OFYR Cozinha Samos	32
OFYR Cozinha Sylt	40
Drawings	54





About the OFYR Plancha

Elevate your outdoor gatherings with the best of wood-fired cooking. The OFYR Plancha transforms the OFYR Cozinha into a symphony of flavours, laughter, and memories. The large cooking surface is made from stainless steel, engineered to distribute the heat of the open fire evenly across its surface. This ensures that every ingredient, from vegetables to meats, receives consistent heat for perfect searing, caramelisation and flavours. The plancha distinguishes itself from other griddles with a downward-sloping cooking surface. This allows excess juices to slide into the fire, preventing the food from burning while keeping the outside nice and crispy.

About the OFYR Plancha

Cooking techniques

By complementing the OFYR Plancha with accessories, the steel plate turns into a grill, oven or cooking hub. Experiment with cooking techniques and unleash your creativity, preparing a wide array of dishes from hearty breakfasts to sweet desserts. Whether you want to cook a 3-course meal for the family or some delicious bites for a party, the OFYR Plancha gives you the ability to achieve exquisite taste and texture every time.



Searing

Quickly sear ingredients on the hot cooking plate, preserving those healthy nutrients and delicious juices.



Grilling

Perfectly scorch meats and veggies directly above the fire with a Grill plate.

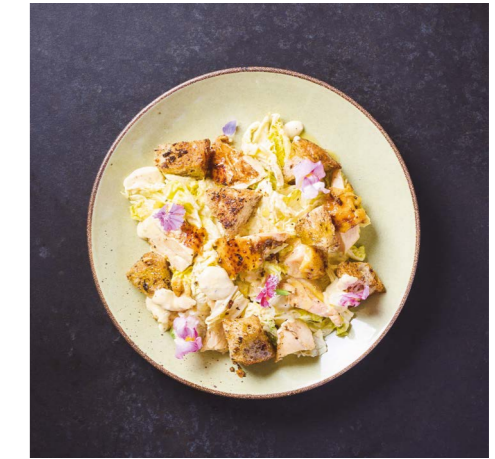

Slow Cooking

Place ingredients a little further away from the fire with the Rotisserie Set and Skewers, to slowly cook them to perfection.

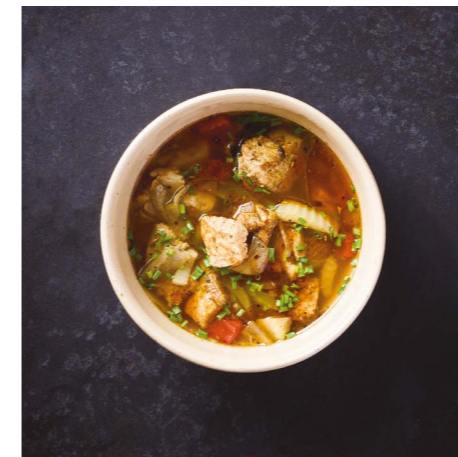

Cooking

From boiling vegetables to preparing soups and sauces, the cooking plate and grill provide a solid surface for cast iron casseroles.

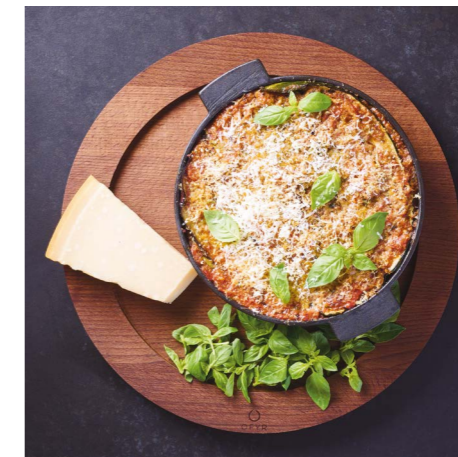

Baking

With the addition of the Pizza Oven, the plancha transforms into an oven to bake everything from pizzas to desserts.

About the OFYR Plancha

The perfect plancha experience

Cooking with the OFYR Plancha begins by making a fire and selecting the finest ingredients, ensuring that only the freshest and most delicious food makes its way onto the plancha's surface. By adding these precision tools, accessories, and protective products, you will set the perfect stage for a remarkable culinary spectacle.

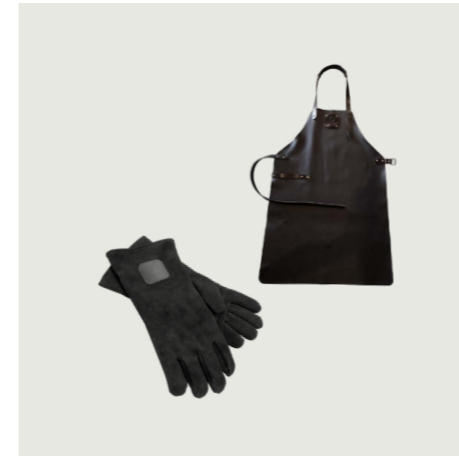

Gloves & Apron

Handle with care. A wood-fired plancha reaches high temperatures, so any cooking session requires protection in the form of the OFYR Gloves and the OFYR Leather Apron.



Spatula

A spatula makes cooking on the OFYR Plancha much easier. Not only is this tool ideal for flipping ingredients but it is also essential to scrape food remnants off the cooking plate.

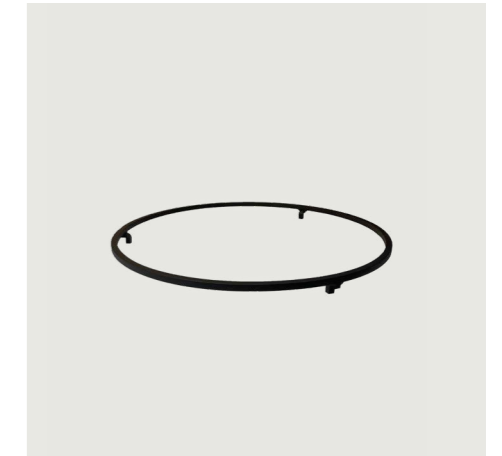

Food Bumper

This nifty tool prevents round or slippery ingredients from sliding into the fire. The OFYR Food Bumper is a barrier on the inner edge, safely keeping the food on the cooking plate.



Grill

There is nothing quite like grilling over an open fire, which is why the OFYR Grill Round is a must-have. Place this tool directly over the fire to grill large cuts of meat, fish and vegetables.

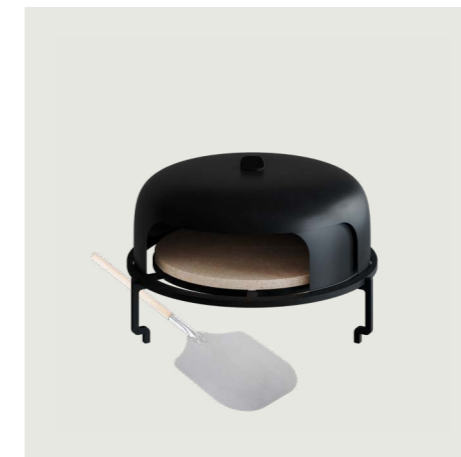

Pizza Oven

This accessory is an oven, griddle, and grill in one. Once you are done baking, you simply remove the cloche to reveal a double-sided grill plate.



Cover

Keep the OFYR Plancha in optimal condition with the OFYR Cover. After cooking, clean and oil the steel plate, then place the cover on top.



About The Bastard Kamado

Experience the epitome of outdoor dining in your OFYR Cozinha with The Bastard VX, a modern reimagining of the ancient Japanese earthenware cooking vessel. This charcoal-fuelled ceramic barbecue combines tradition with cutting-edge technology, creating a versatile cooking experience. With the help of some accessories, the kamado lends itself to techniques like grilling, searing, baking, and smoking all types of ingredients and dishes. To help you get started cooking right away, The Bastard VX includes 2 half grills, 2 half plate setters, a coal basket and an ash lifter. From the black thermometer and innovative top cap to a large and strong firebox, this kamado exudes perfection to the very last detail.

About The Bastard Kamado

Cooking techniques

The Bastard VX is more than just a barbecue: it is a culinary powerhouse. Its innovative design allows for precise temperature control, providing the ideal conditions for low-and-slow smoking, high-temperature searing, and everything in between. By adding accessories to your collection, you can cook and bake a variety of dishes, from roasts to pizzas and desserts. The excellent heat retention and circulation create an environment that preserves moisture and flavour, resulting in mouth-watering dishes every time.

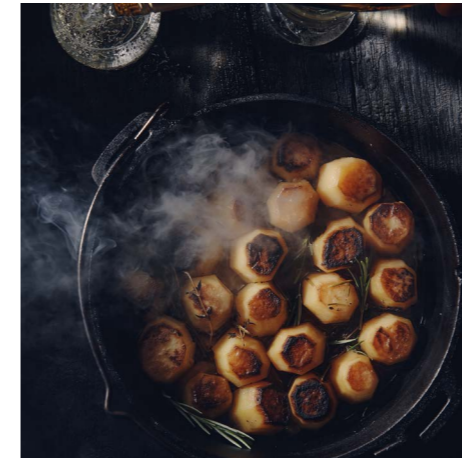

Smoking

Infuse that delicious smoky aroma into your ingredients with different types of charcoal.

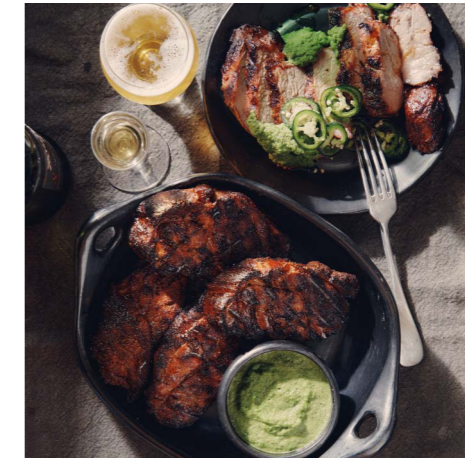

Grilling

Get that perfect char every time with the multi-level grill system.



Slow Cooking

Find that sweet spot and let the indirect heat work its magic for optimal flavour.



Roasting

There's nothing like meat with juicy and tender insides and an incredibly flavourful crisp on the outside.



Baking

From the most delicious pizzas to your favourite veggies, use the VX tools to bake them to perfection.

About The Bastard Kamado

The perfect kamado experience

The OFYR Cozinha models that feature The Bastard VX, will already include some basic VX tools like 2 half-moon grills, 2 half-moon plate setters and an ashtray. Complement your culinary journey with these recommended accessories to facilitate all your cooking sessions.



The VX Tools

Your starter kit for cooking with the ceramic barbecue consists of The Bastard VX Spatula, Meat Flipper and Tong. Ideal for flipping or tussling any type of ingredient.



One Minute Lighter

Bring your ceramic barbecue to life with just a simple touch. The One Minute Lighter makes lighting the charcoal much easier and helps you to safely stoke up the fire while you are cooking.



Half Moon Griddle

Discover multi-level cooking with the Half Moon Griddle. The flat side of this double-sided griddle is ideal for quick searing, while the ribbed side creates those perfect grill marks.



Dutch Oven

From hearty stews to homemade sourdough bread, with this casserole you can make it all. Use the lid as a griddle to quickly sear meats or vegetables before they go into the casserole.

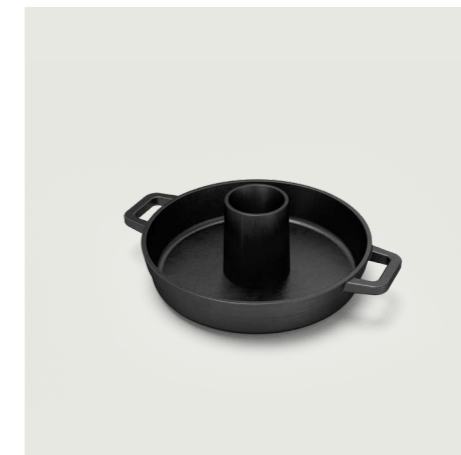

Bird Sitter

The Bird Sitter is a must-have accessory to create a full meal. Simply put a chicken on the protruding part in the middle and surround it with some potatoes and vegetables.



Cast-Iron Grid

Cast iron gives a more constant heat than stainless steel and conducts better, making this Grid ideal for grilling at high temperatures.

Materials

All products of the OFYR Cozinha collection are crafted with meticulous attention to detail and premium materials. Our models feature various finishes and options to create the outdoor kitchen of your dreams.

Base

The foundation of the outdoor kitchens is an elegant base made of powder-coated aluminium, ensuring durability and resistance to the elements. This corrosion-resistant material guarantees longevity and maintains a sleek, modern appearance that complements any outdoor setting.

Colours

For added personalisation, the base and countertop are available in 2 distinct colourways. The colours are chosen to blend perfectly into the existing surroundings, while also drawing attention to the exquisite design.

- ***Pietra Anversa countertop + Graphite base***
- ***Pietra Milano countertop + Taupe base***

Countertop

All culinary activities start with the stunning ceramic countertop. The refined finish adds a touch of sophistication and offers exceptional heat resistance. Each kitchen features a large cooking surface, providing ample space for meal preparation and presentation.



Pietra Anversa

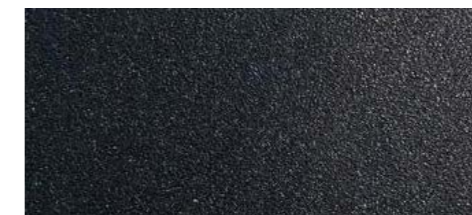

Graphite

Sink

Each outdoor can be complemented with a sink. This component is crafted from high-quality stainless steel, designed to withstand the rigours of outdoor use. The sink provides easy maintenance and a hygienic environment for food preparation and clean-up.



Pietra Milano



Taupe

OFYR Cozinha Elba



OFYR Cozinha Elba

Kamado VX

OFYR Cozinha Elba is the perfect choice for everyday cooking and small gatherings. Its compact size and contemporary style are carefully designed to fit into any outdoor space. Use this model as a free-standing kitchen island or place it alongside a wall for a clean look. This kitchen features The Bastard VX, a culinary marvel that empowers you to explore a wide array of cooking techniques. The kamado can be positioned on the left side, in the middle, or on the right side, granting you the flexibility to configure your outdoor kitchen according to your preferences.

This design is available in the colourways Pietra Anversa countertop with a graphite base and a Pietra Milano countertop with a taupe base. The base consists of 2 cabinets and a cooking module with a small storage space underneath the ceramic barbecue. Complement the base with the optional built-in sink for optimal functionality. Whichever options you choose, your outdoor kitchen will radiate elegance and sophistication, becoming a true extension of your home.

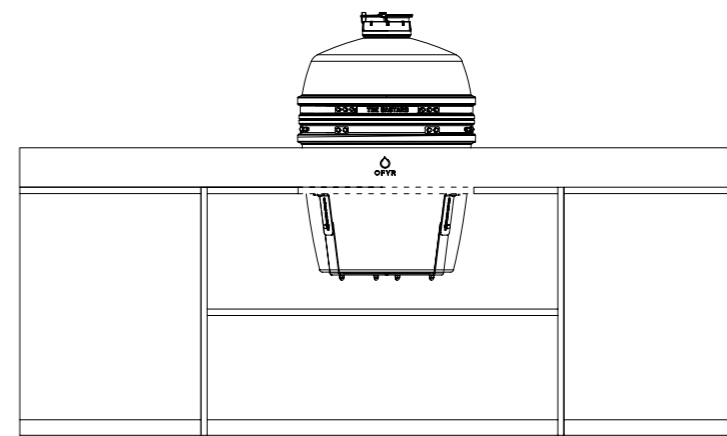

SPECIFICATIONS

● PIETRA ANVERSA / GRAPHITE ● PIETRA MILANO / TAUPE

		● PIETRA ANVERSA / GRAPHITE	● PIETRA MILANO / TAUPE
Materials	Grill Plate	Steel	Steel
	Kamado	Cordierite ceramic	Cordierite ceramic
	Sink	Stainless steel	Stainless steel
	Countertop	Ceramic	Ceramic
	Base	Powder coated aluminium	Powder coated aluminium
Dimensions	Cooking surface	Ø49 cm	Ø49 cm
	Kamado	Ø56x87 cm	Ø56x87 cm
	Sink	57x51x23 cm	57x51x23 cm
	Cooking module	120x95x83 cm	120x95x83 cm
	Cabinets	120x95x83 cm	180x95x83 cm
	Countertop	240x95x10 cm	240x95x10 cm
	Total	240x95x93 cm	240x95x93 cm
Weight	Grill plate	9 kg	9 kg
	Kamado	83 kg	83 kg
	Sink	13.4 kg	13.4 kg
	Countertop	80 kg	80 kg
	Base	110 kg	110 kg
	Total	295.4kg	295.4kg
		With sink cut-out 285.4 kg	With sink cut-out 285.4 kg

OFYR Cozinha
Elba Kamado VX
Left



OFYR Cozinha
Elba Kamado VX
Center



OFYR Cozinha
Elba Kamado VX
Right



OFYR Cozinha
Elba VX Kamado
Left with Sink



OFYR Cozinha
Elba Kamado VX
Center with Sink



OFYR Cozinha
Elba Kamado VX
Right with Sink





OFYR Cozinha Samos



OFYR Cozinha Samos

Kamado VX

Commanding attention with its generous size, the OFYR Cozinha Samos blends a luxurious design with unparalleled functionality. This kitchen is ideal for large outdoor spaces, catering to all your culinary needs with The Bastard VX, ample storage space and a large countertop. In this design, the kamado is always positioned in the centre of the base to ensure an effortless workflow during cooking. Whether you place the kitchen alongside a wall or use it as a kitchen island, its elegant lines blend seamlessly with any outdoor style.

OFYR Cozinha Samos is available in the colourways Pietra Anversa countertop with a graphite base and a Pietra Milano countertop with a taupe base. The base consists of 4 cabinets and a cooking module with additional storage space underneath the cooking unit. If you choose to complement the kitchen with an integrated sink, this module will always be added on the outer right side. With its spacious cabinets, expansive cooking surface and ceramic barbecue, this kitchen sets a new standard for outdoor entertainment and culinary excellence.

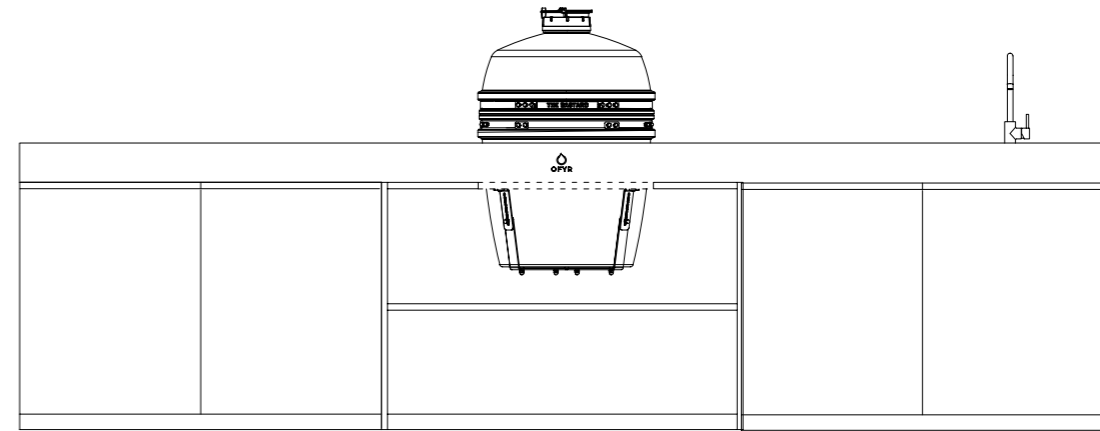

SPECIFICATIONS

● PIETRA ANVERSA / GRAPHITE ● PIETRA MILANO / TAUPE

		● PIETRA ANVERSA / GRAPHITE	● PIETRA MILANO / TAUPE
Materials	Grill Plate	Steel	Steel
	Kamado	Cordierite ceramic	Cordierite ceramic
	Sink	Stainless steel	Stainless steel
	Countertop	Ceramic	Ceramic
	Base	Powder coated aluminium	Powder coated aluminium
Dimensions	Cooking surface	Ø49 cm	Ø49 cm
	Kamado	Ø56x87 cm	Ø56x87 cm
	Sink	57x51x23 cm	57x51x23 cm
	Cooking module	120x95x83 cm	120x95x83 cm
	Cabinets	240x95x83 cm	240x95x83 cm
	Countertop	360x95x10 cm	360x95x10 cm
	Total	360x95x93 cm	360x95x93 cm
Weight	Grill plate	9 kg	9 kg
	Kamado	83 kg	83 kg
	Sink	13.4 kg	13.4 kg
	Countertop	120 kg	120 kg
	Base	136 kg	136 kg
	Total	361.4 kg	361.4 kg
		With sink cut-out 351.4 kg	With sink cut-out 351.4 kg

OFYR Cozinha
Samos Kamado VX



OFYR Cozinha
Samos Kamado VX
with Sink





OFYR Cozinha Sult

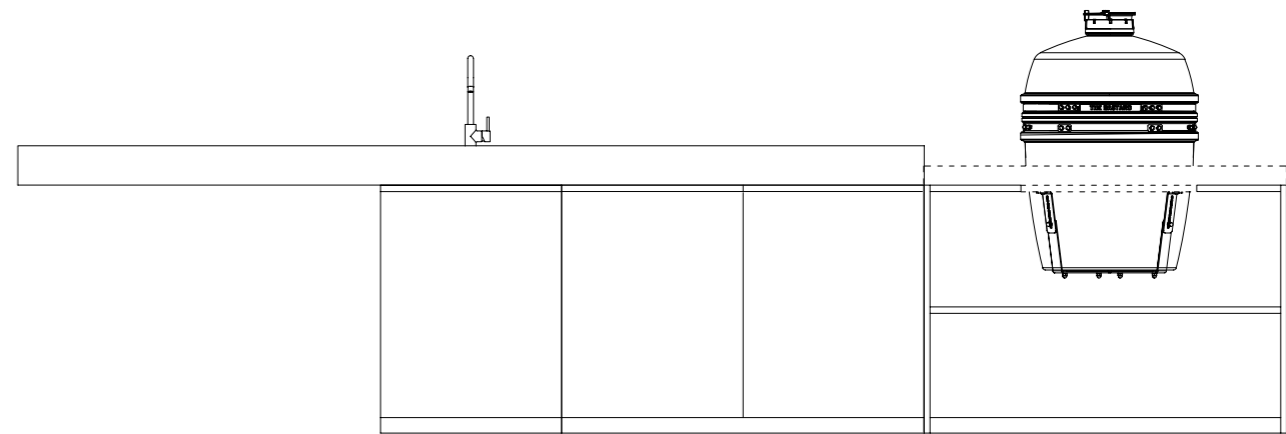

OFYR Cozinha Sylt

Kamado VX

Indulge in the ultimate culinary experience with OFYR Cozinha Sylt. Featuring both a cooking unit and an integrated bar, this model redefines the concept of outdoor cooking and entertaining. The inviting design allows family and friends to cook and dine together, turning your outdoor space into an exquisite extension of your home.

This kitchen island consists of 3 cabinets, The Bastard VX and a bar module for 4 to 5 people at perfect seating height. The cooking and bar modules are always placed on opposite ends, either on the outer left or outer right side of the kitchen. The optional integrated sink will always be placed next to the bar module.

OFYR Cozinha Sylt is available in the colourways Pietra Anversa countertop with a graphite base and a Pietra Milano countertop with a taupe base. It is designed to be used as a free-standing kitchen, with generous storage space and a large work surface. The refined details turn this outdoor kitchen into the perfect backdrop for parties, family gatherings and unforgettable memories.

SPECIFICATIONS

● PIETRA ANVERSA / GRAPHITE ● PIETRA MILANO / TAUPE

		● PIETRA ANVERSA / GRAPHITE	● PIETRA MILANO / TAUPE
Materials	Grill Plate	Steel	Steel
	Kamado	Cordierite ceramic	Cordierite ceramic
	Sink	Stainless steel	Stainless steel
	Countertop	Ceramic	Ceramic
	Base	Powder coated aluminium	Powder coated aluminium
Dimensions	Cooking surface	Ø49 cm	Ø49 cm
	Kamado	Ø56x87 cm	Ø56x87 cm
	Sink	57x51x23 cm	57x51x23 cm
	Cooking module	120x95x83 cm	120x95x83 cm
	Cabinets	180x95x83 cm	180x95x83 cm
	Countertop	300x95x10 cm	300x95x10 cm
	Total	420x95x93 cm	420x95x93 cm
Weight	Grill plate	9 kg	9 kg
	Kamado	83 kg	83 kg
	Sink	13.4 kg	13.4 kg
	Countertop	100 kg	100 kg
	Base	123 kg	123 kg
	Total	328.4 kg	328.4 kg
		With sink cut-out 318.4 kg	With sink cut-out 318.4 kg

OFYR Cozinha
Sylt Kamado VX
Left



OFYR Cozinha
Sylt Kamado VX
Left with Sink



OFYR Cozinha
Sylt Kamado VX
Right



OFYR Cozinha
Sylt Kamado VX
Right with Sink





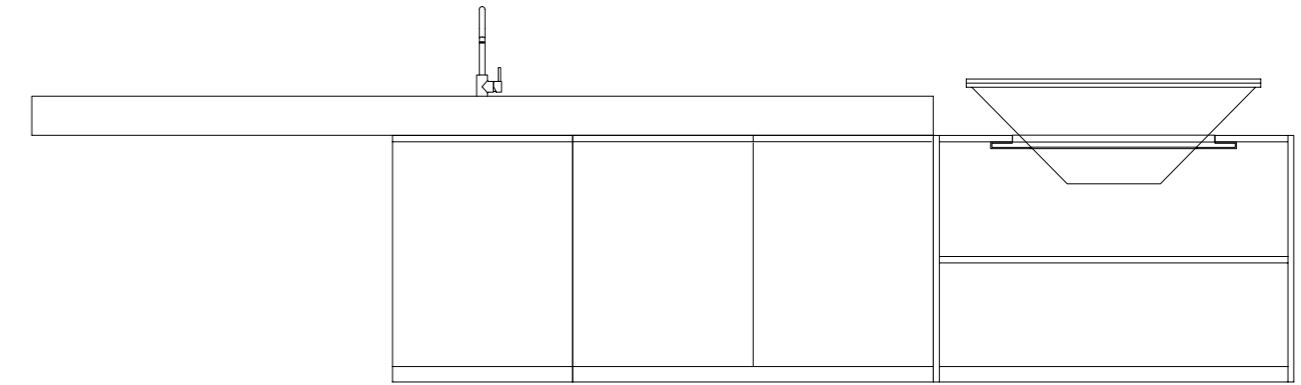

OFYR Cozinha Sylt

OFYR Plancha

Indulge in the ultimate culinary experience with OFYR Cozinha Sylt. Featuring both a cooking unit and an integrated bar, this model redefines the concept of outdoor cooking and entertaining. The inviting design allows family and friends to cook and dine together, turning your outdoor space into an exquisite extension of your home.

This kitchen island consists of 3 cabinets, an OFYR Plancha and a bar module for 4 to 5 people at perfect seating height. The cooking and bar modules are always placed on opposite ends, either on the outer left or outer right side of the kitchen. The optional integrated sink will always be placed next to the bar module.

OFYR Cozinha Sylt is available in the colourways Pietra Anversa countertop with a graphite base and a Pietra Milano countertop with a taupe base. It is designed to be used as a free-standing kitchen, with generous storage space and a large work surface. The refined details turn this outdoor kitchen into the perfect backdrop for parties, family gatherings and unforgettable memories.

SPECIFICATIONS

● PIETRA ANVERSA / GRAPHITE ● PIETRA MILANO / TAUPE

Materials	Cooking plate	Black steel	Black steel
	Cone	Black coated steel	Black coated steel
	Sink	Stainless steel	Stainless steel
	Countertop	Ceramic	Ceramic
	Base	Powder coated aluminium	Powder coated aluminium
Dimensions	Cooking surface	0,55 m ²	0,55 m ²
	Cooking plate	Ø98x1.2 cm	Ø98x1.2 cm
	Sink	57x51x23 cm	57x51x23 cm
	Cooking module	120x65x83 cm	120x65x54 cm
	Cabinets	180x65x83 cm	180x65x83 cm
	Countertop	300x65x10 cm	300x65x10 cm
	Total	420x65x93 cm	420x65x93 cm
Weight	Cooking plate	56 kg	56 kg
	Cone	20 kg	20 kg
	Sink	13.4 kg	13.4 kg
	Countertop	67 kg	67 kg
	Base	118 kg	118 kg
	Total	274,4 kg	274,4 kg
		With sink cut-out 264.4 kg	With sink cut-out 264.4 kg

OFYR Cozinha
Sylt OFYR Plancha
Left



OFYR Cozinha
Sylt OFYR Plancha
Left with Sink



OFYR Cozinha
Sylt OFYR Plancha
Right



OFYR Cozinha
Sylt OFYR Plancha
Right with Sink





OFYR Cozinha
Elba Kamado VX
Left

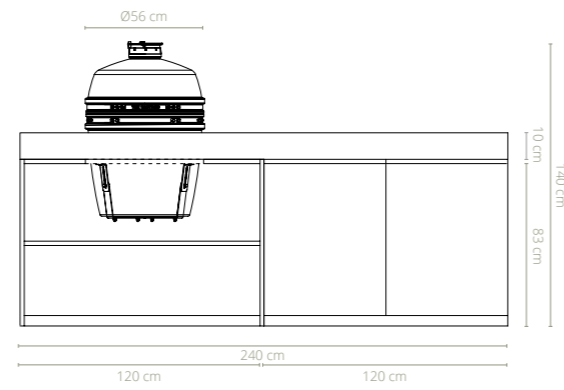

OFYR Cozinha
Elba VX Kamado
Left with Sink

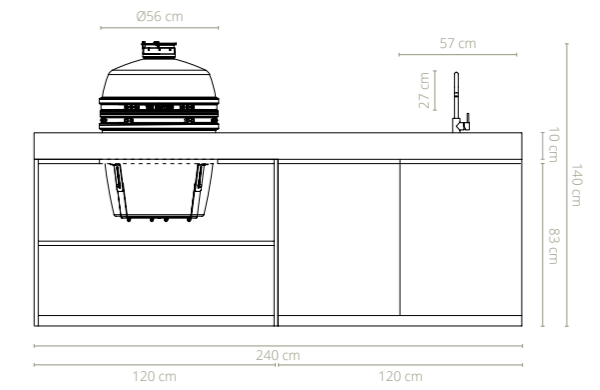

OFYR Cozinha
Elba Kamado VX
Center

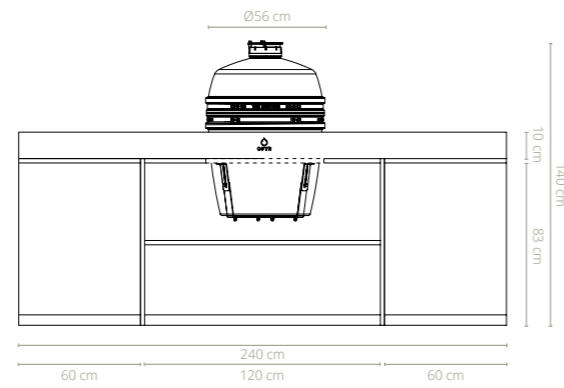

OFYR Cozinha
Elba Kamado VX
Center with Sink

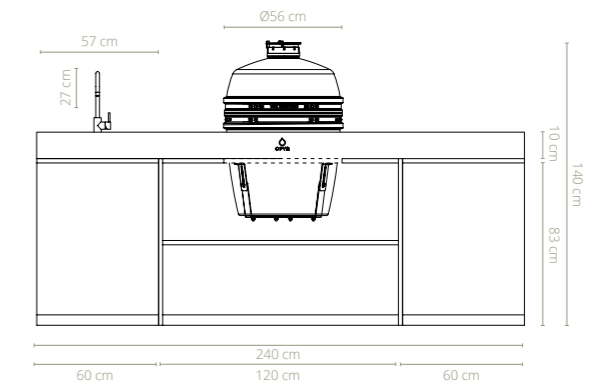

OFYR Cozinha
Elba Kamado VX
Right

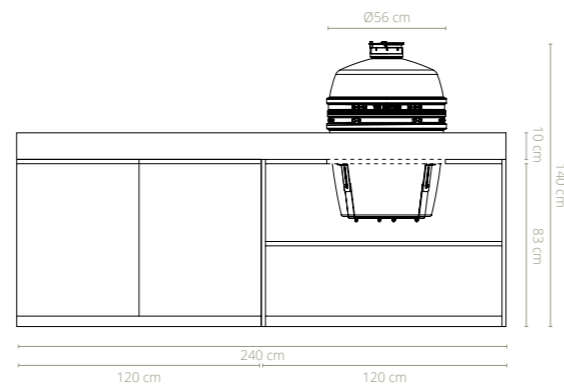

OFYR Cozinha
Elba Kamado VX
Right with Sink

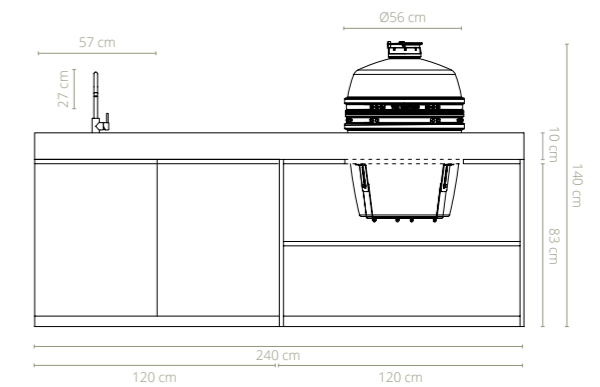

OFYR Cozinha
Samos Kamado VX

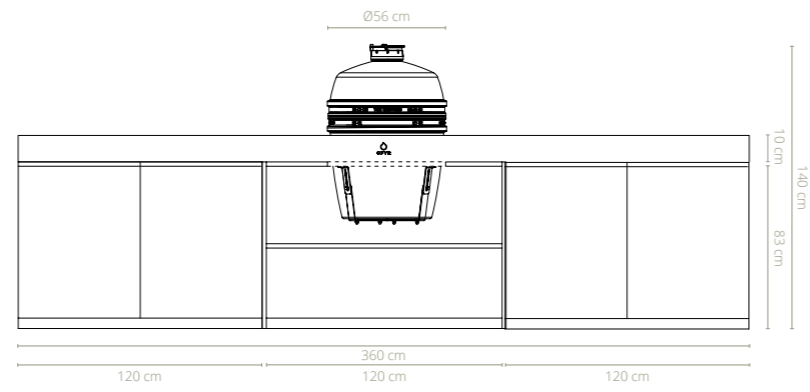

OFYR Cozinha
Samos Kamado VX
with Sink

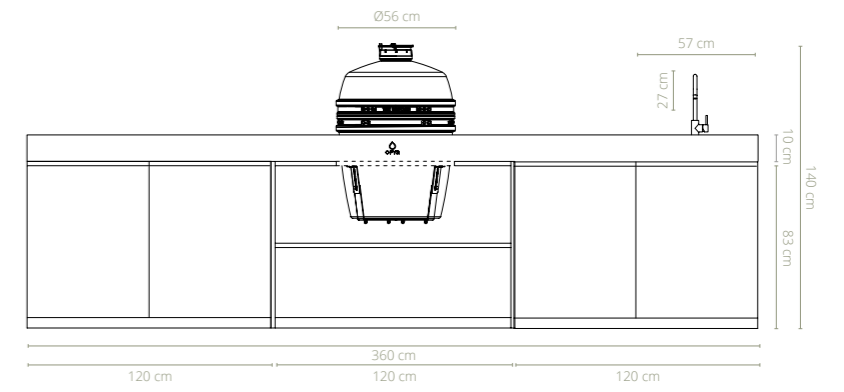

OFYR Cozinha
Sylt Kamado VX
Left

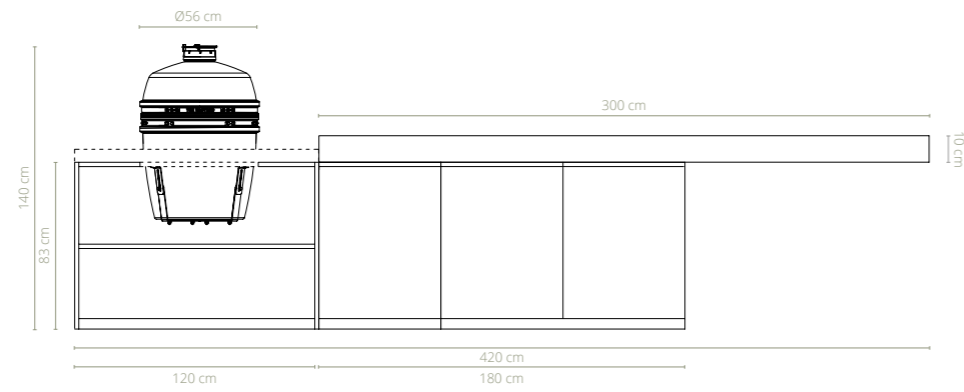

OFYR Cozinha
Sylt Kamado VX
Left with Sink

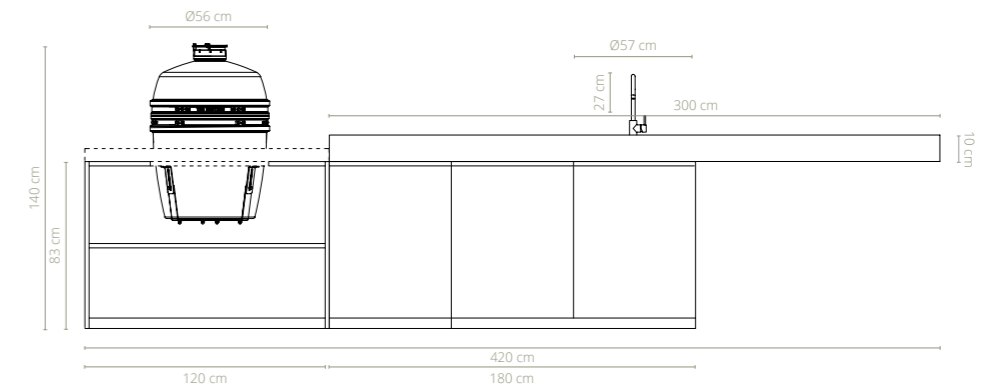

OFYR Cozinha
Sylt Kamado VX
Right

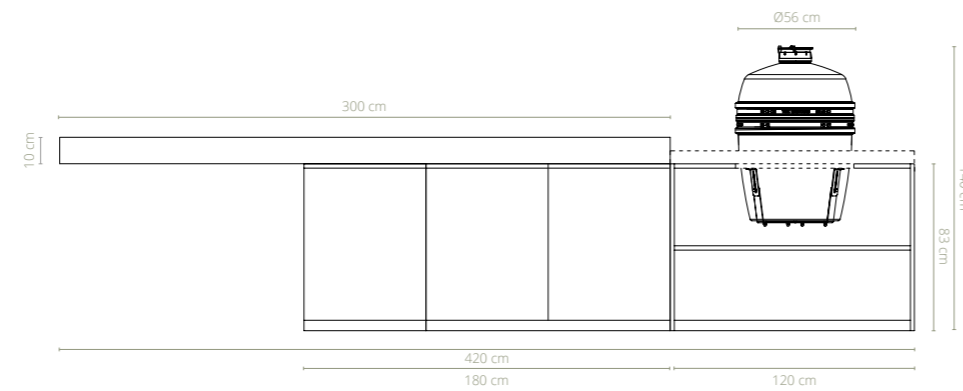

OFYR Cozinha
Sylt Kamado VX
Right with Sink

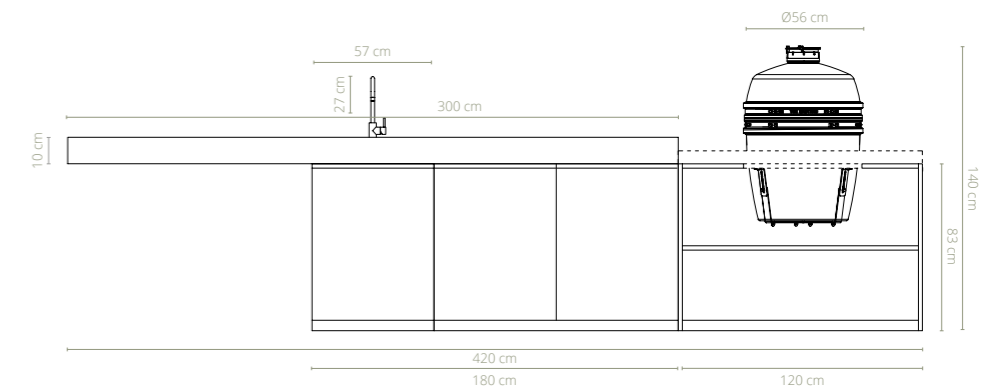

OFYR Cozinha
Sylt OFYR Plancha
Left

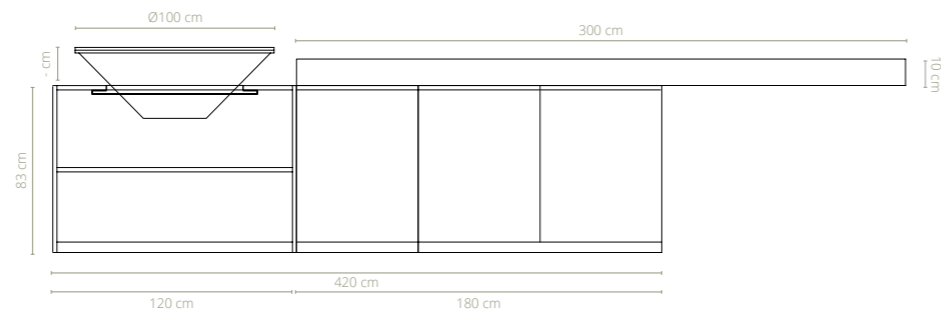

OFYR Cozinha
Sylt OFYR Plancha
Left with Sink

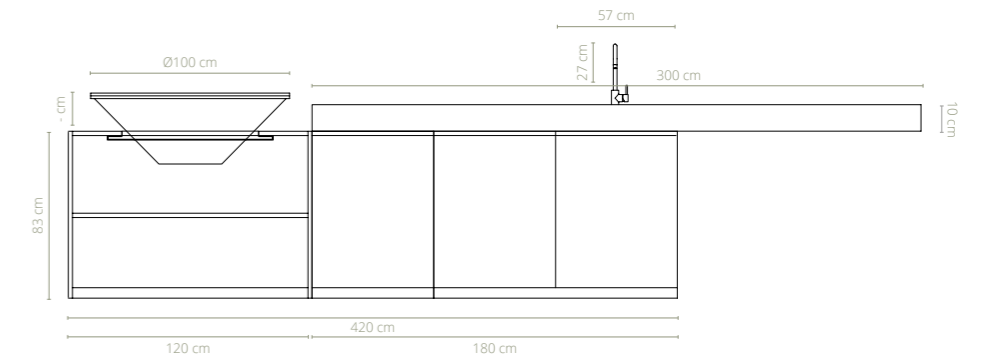

OFYR Cozinha
Sylt OFYR Plancha
Right

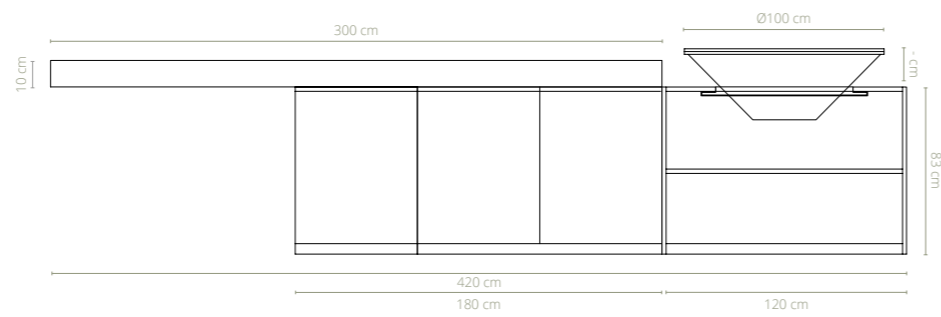

OFYR Cozinha
Sylt OFYR Plancha
Right with Sink

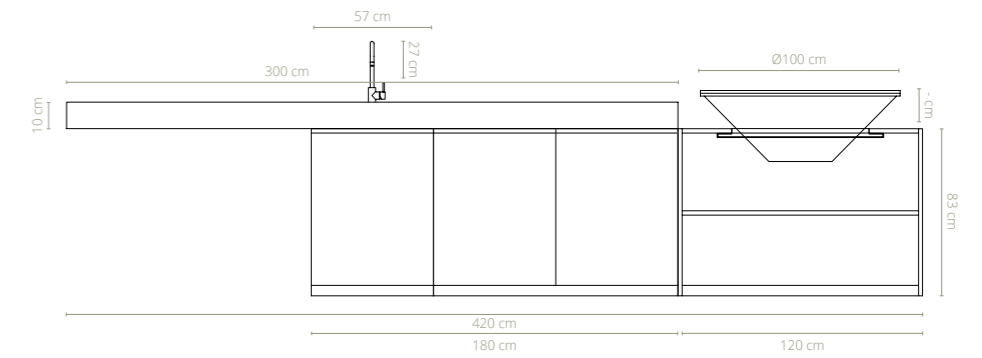

Colophon

Text

Annika van den Brink

Design

Simone de Kock

Photography

Fyron Group B.V.

Renders

Nudesign

Printing

Damen Drukkers

Published by

Fyron Group B.V.

Copyright

Fyron Group B.V.

All rights reserved.

No part of this publication may be reproduced or distributed in any form or by any method without the express written consent of the publisher.

This publication has been compiled with the greatest care. Nevertheless, neither the author nor publisher can be held liable for any damages resulting from any inaccurate or incomplete information contained therein.



OFYR IS PART OF THE FYRON GROUP - WWW.FYRONGROUP.COM



